



OPTO ENGINEERING



INSTRUCTIONS MANUAL

# MZMT12X Series

12X continuous macro zoom lenses  
with motorized control



## Table of contents

1. Disclaimer .....	pag. 3
2. Safety Notes .....	pag. 3
3. General Description .....	pag. 3
3.1 Content of delivery .....	pag. 4
3.2 Specification .....	pag. 4
4. Instructions for use .....	pag. 5
4.1 Installation .....	pag. 5
4.2 Connections .....	pag. 5
5. Getting Started .....	pag. 6
5.1 Download lens XML file .....	pag. 6
5.2 Connect the device .....	pag. 6
5.3 MZMT12X focusing operations .....	pag. 6
5.4 MZMT12X optical groups motion .....	pag. 7
5.5 Homing procedure .....	pag. 7
5.6 Operating the coaxial light.....	pag. 7
6. CE Conformity .....	pag. 8

## 1. Disclaimer

Always deploy and store Opto Engineering® products in the prescribed conditions in order to ensure proper functioning; failing to comply with the following conditions may shorten the product lifetime and/or result in malfunctioning, performance degradation or failure.

Ensure that incorrect functioning of this equipment cannot cause any dangerous situation or significant financial loss to occur. It is essential that the user ensures that the operation of the product is suitable for his/her application. All trademarks

mentioned herein belong to their respective owners.

Except as prohibited by law:

- All hardware, software and documentation is provided on an “as is” basis.
- Opto Engineering® accepts no liability for consequential loss, of any kind.

Upon receiving your Opto Engineering® product, visually examine the product for any damage during shipping. If the product is damaged upon receipt, please notify Opto Engineering® immediately.

## 2. Safety Notes

- ➔ **Read carefully this instructions manual**  
This document contains the necessary information to use the product properly.
- ➔ **Do not inspect the internal parts of the product. Warranty will not be valid if product is opened**  
MZMT12X series lenses contain very delicate components that might be permanently damaged if handled carelessly.
- ➔ **Product must be adequately shielded if employed in dusty and humid places**
- ➔ **Do not use together with machines that generate strong vibrations**  
MZMT12X series lenses might be permanently damaged if deployed in the presence of strong vibrations and impulsive forces.
- ➔ **MZMT12X series lenses must be properly clamped before usage**  
The product must be mechanically constrained by adequate clamping system.
- ➔ **Do not use the product out of the fields of usage marked in the specifications**  
See the “Specifications” paragraph for further information.

## 3. General Description

MZMT12X series includes high resolution motorized macro zoom lenses featuring excellent optical performances in a compact and robust design.

Two main models are available: 12X macro zoom lenses with and without coaxial illumination designed for 2/3” detectors.

Opto Engineering® motorization design integrates two bipolar stepper motors that control zooming and focusing with fine incremental movements and accurate repetitive positioning.

MZMT12X macro zoom lenses are complemented by dedicated stepper motor controller MTDV to be purchased separately.

All of these features make these zoom lenses perfect for all those offline and inline applications requiring changes of format and high-quality images at fixed working distance.

## 3.1 Content of delivery

MZMT12X series macro zoom lens.

## 3.2 Specification

Part number	Mag.	Image circle Ø (mm)	Detector type					
			1/3" w x h (mm x mm)	1/2.5" w x h (mm x mm)	1/2" w x h (mm x mm)	1/1.8" w x h (mm x mm)	2/3" - 5 Mpx w x h (mm x mm)	
			<b>Object field of view (mm x mm) 1</b>					
MZMT 23A12X-C	max	7.2	11.0	0.70 x 0.50	0.80 x 0.60	0.90 x 0.70	1.00 x 0.70	1.20 x 1.00
	mid	2.5	11.0	1.90 x 1.40	2.30 x 1.70	2.60 x 1.90	2.90 x 2.10	3.40 x 2.80
	min	0.6	11.0	8.00 x 6.00	9.50 x 7.10	10.7 x 8.00	11.9 x 9.00	14.1 x 11.8
MZMTCX 23A12X-C-W	max	7.2	11.0	0.70 x 0.50	0.80 x 0.60	0.90 x 0.70	1.00 x 0.70	1.20 x 1.00
	mid	2.5	11.0	1.90 x 1.40	2.30 x 1.70	2.60 x 1.90	2.90 x 2.10	3.40 x 2.80
	min	0.6	11.0	8.00 x 6.00	9.50 x 7.10	10.7 x 8.00	11.9 x 9.00	14.1 x 11.8
MZMTCX 23A12X-C-G	max	7.3	11.0	0.70 x 0.50	0.80 x 0.60	0.90 x 0.70	1.00 x 0.70	1.20 x 1.00
	mid	2.5	11.0	1.90 x 1.40	2.30 x 1.70	2.60 x 1.90	2.90 x 2.10	3.40 x 2.80
	min	0.6	11.0	8.00 x 6.00	9.50 x 7.10	10.7 x 8.00	11.9 x 9.00	14.1 x 11.8

Part number	WD (mm)	wF/#	Optical specifications		
			Dist. typ (max) (%)	Field depth min (mm)	CTF (%)
	<b>2</b>	<b>3</b>	<b>4</b>	<b>5</b>	
MZMT 23A12X-C	max	31	< 0.25 (0.3)	0.03	> 25% @20lp/mm
	mid	83.0	< 0.05 (0.1)	0.18	> 40% @50lp/mm
	min	12	< 0.2 (0.25)	1.73	> 30% @50lp/mm
MZMTCX 23A12X-C-W	max	31	< 0.25 (0.3)	0.03	> 25% @20lp/mm
	mid	83.0	< 0.05 (0.1)	0.18	> 40% @50lp/mm
	min	12	< 0.2 (0.25)	1.73	> 30% @50lp/mm
MZMTCX 23A12X-C-G	max	31	< 0.25 (0.3)	0.03	> 25% @20lp/mm
	mid	83.0	< 0.05 (0.1)	0.18	> 40% @50lp/mm
	min	12	< 0.2 (0.25)	1.73	> 30% @50lp/mm

Part number	Electrical specs	Mechanical specs			
	Coaxial light	Mount	Length (mm)	Width	Height (mm)
			<b>6</b>		
MZMT 23A12X-C	no	C	300	70	73
MZMTCX 23A12X-C-W	white	C	300	70	171
MZMTCX 23A12X-C-G	green, 520 nm	C	300	70	171

- 1 For the fields with the indication "Ø =", the image of a circular object of such diameter is fully inscribed into the detector.
- 2 Working distance: distance between the front end of the mechanics and the object. Set this distance within +/- 3% of the nominal value for maximum resolution and minimum distortion.
- 3 Working F-number (wF/#): the real F-number of a lens when used as a macro. wF/# is fixed at a specific magnification. wF/# changes when magnification is changed.
- 4 Percent deviation of the real image compared to an ideal, undistorted image. Absolute values are listed.
- 5 At the borders of the field depth the image can be still used for measurement but, to get a very sharp image, only half of the nominal field depth should be considered. Pixel size used for calculation is 5.5 µm.
- 6 Measured from the front end of the mechanics to the camera flange.

## 4. Instructions for use

### 4.1 Installation

The lens must be mounted on a rigid support by means of adequate clamps. Specifically, it must be constrained in the spaces labelled as “clamping diameter”. Clamping the product in other positions might seriously damage internal components and alter the overall optical performance.

Use the CMHO024 mechanical clamp for safer and accurate mounting.

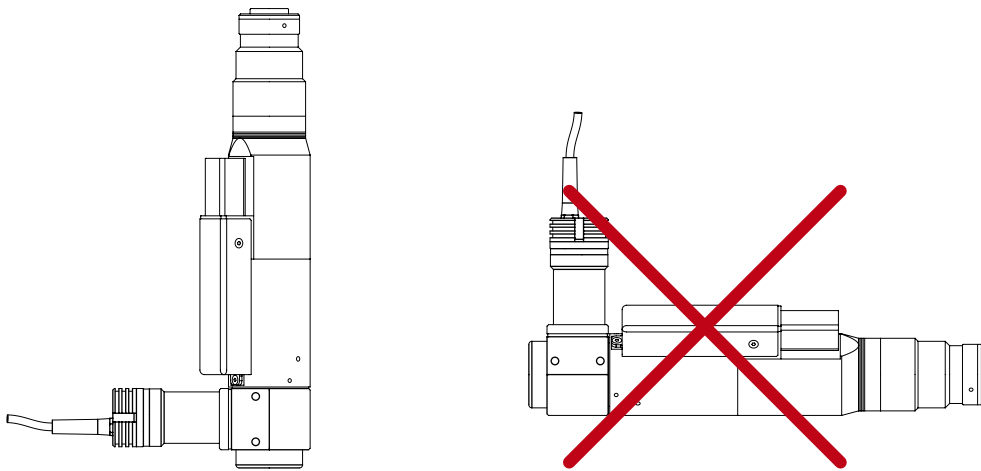

MZMT12X series lenses must be operated according to the drawing above. Only vertical operations are allowed. MZMT12X series lenses might not to work properly or might be permanently damaged if used horizontally.

### 4.2 Connections

MZMT12X macro zoom lenses need to be connected to a motion controller. Cable CBMT001 (sold separately) can be used to connect a MZMT12X lens to a MTDV motion controller (sold separately). See MTDV user manual for information on MTDV motion controller connections.

## 5. Getting Started

### 5.1 Download lens XML file

Each MZMT12X macro zoom lens has its own configuration XML file. Such a file can be used to properly configure MTDV motion controller to ensure the better user experience. Configuration files can be downloaded from [www.opto-engineering.com/configuration\\_files](http://www.opto-engineering.com/configuration_files). Simply digit the lens serial number and the Opto Security Number, then click the SUBMIT button. MTSW software allows the user to load XML file into the MTDV motion controller. Please see MTSW user manual for further details.

### 5.2 Connect the device

MZMT12X macro zoom lenses need to be connected to a motion controller. Opto Engineering® MTDV series motion controllers (sold separately) can be used to simply control the lens using CBMT001 cable (sold separately).

### 5.3 MZMT12X focusing operations

After clamping the lens please adjust the working distance until it is equal to its nominal value. Use MTDV to control lens motors.

Each motor moves an optical group inside the lens. Both optical groups contribute to zooming and focusing operations. At high magnification (i.e. at low motors positions) motor 1 acts as the zoom motor and motor 2 acts as the focusing motor. Vice versa, at low magnification (i.e. at high motors positions) motor 2 acts as the zoom motor and motor 1 acts as the focusing motor.

**Note that optical groups inside the lens might collide** since their motion is independent and their strokes overlap.

MZMT12X lens might not to work properly or might be permanently damaged after optical groups collision.

To prevent collisions, you can follow following simple tips:

- Do not set different speeds and accelerations for each motor.
- Use the look up table contained in the XML file to know which are the motors positions to achieve listed magnifications. If you use MTSW software and you load the XML file, the look up table will be loaded into your MTDV motion controller. You can use "Load Positions" function to load preset positions. Please read MTSW and MTDV user manuals for further information.
- If possible, move both motors at the same time.
- If you need to move motors one by one, and you need to increase their positions, move motor 1 first and then motor 2. Vice versa, if you need to decrease their positions, move motor 2 first and then motor 1.
- Do not execute the "homing" of the only motor 1 unless motor 2 is homing itself or it's at position 0
- At magnification 2.4x the optical groups reach their minimum distance. Pay attention if you are working at that magnification.

## 5.4 MZMT12X optical groups motion

When you load the XML file into the MTDV, the motion controller is properly configured to minimize backlash.

Every motion system has its own backlash due to motor's internal gearing and drive system clearance. In order to minimize the backlash effect on the repeatability, the MTDV will act in two different ways: when the position is increasing it will drive the motor to the desired position. When the position is decreasing, it will overshoot the target position and then it will drive back the motor to the desired position. This behavior allows an accurate repetitive positioning by minimizing the backlash effect.

## 5.5 Homing procedure

MZMT12X lenses don't have any limit sensor. The homing procedure is the process of positioning a motor to its mechanical stop that corresponds to "0" position. Since there is no sensor, the MTDV will drive each motor for its complete stroke (plus an extra stroke), independently from its starting position. It means that homing time is fixed. Mechanics is designed to guarantee a very reliable homing procedure.

## 5.6 Operating the coaxial light

Coaxial light can be operated in two ways:

- standard usage option: through the built-in electronics
- direct LED control usage option

### 5.6.1 STANDARD usage option (LED control through built-in electronics)

Only continuous mode (constant voltage) is allowed.

#### Connection

Connect the black and brown cables to your +12 / +24 V power supply.

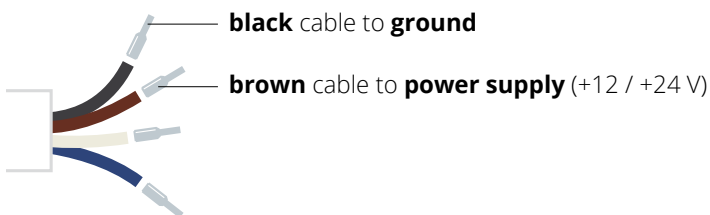

### Light intensity adjustment

The built-in multi-turn trimmer allows to control the light (LED forward current) intensity with a very high degree of precision: you can bring the current intensity from minimum to maximum with 21 full turns of the adjustment screw. Simply remove the protective cap and rotate **counter-clockwise** the adjustment screw to increase light intensity and vice versa.

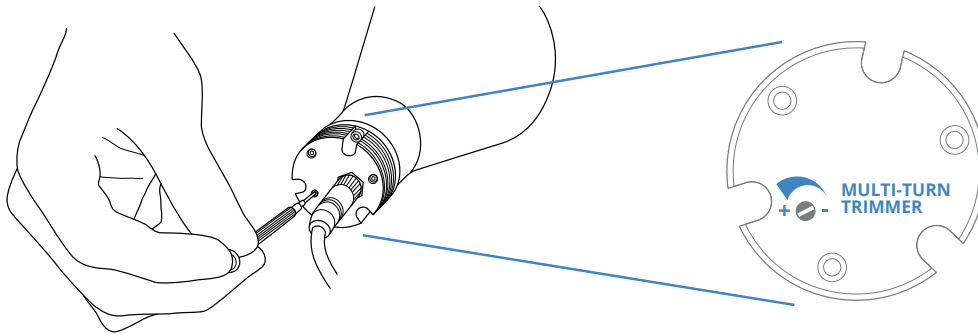

### 5.6.2 Direct LED control usage option

Both continuous and pulsed mode are allowed; the built-in electronics can be bypassed in order to drive the LED directly for use in continuous or pulsed mode. When bypassed, built-in electronics behaves as an open circuit allowing direct control of the LED source. Please note that in such case light intensity adjustment is not possible though the built-in multi-turn trimmer.

#### Connection

Connect the black and blue cables as shown below (remove the LED anode protective cover):

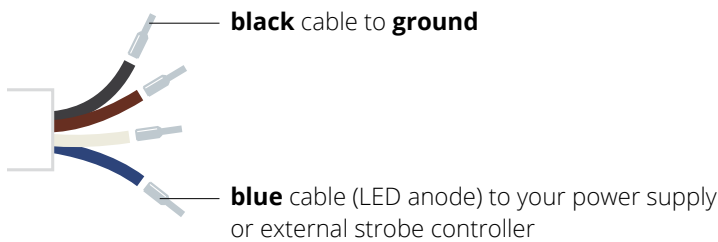

! Make sure not to exceed  
• LEDs maximum rates to avoid electrical shorts.

## 6. CE Conformity

Opto Engineering® declares that product MZMT12X series complies with the provisions of the Community Directive 20014/30/CE (EMC)





**OPTO ENGINEERING**

[www.opto-engineering.com](http://www.opto-engineering.com)

## CONTACT US

### EUROPE

#### **Opto Engineering Europe Headquarters**

Circonvallazione Sud, 15  
46100 Mantova, IT  
phone: +39 0376 699111  
[eu@opto-engineering.com](mailto:eu@opto-engineering.com)

#### **Opto Engineering Germany**

Marktplatz 3  
82031 Grünwald  
phone: +49 (0)89 693 9671-0  
[de@opto-engineering.com](mailto:de@opto-engineering.com)

#### **Opto Engineering Russia**

*official partner*  
ViTec Co., Ltd, Fontanka emb., 170,  
Saint-Petersburg, 198035, RU  
phone: +7 812 5754591  
[info@vitec.ru](mailto:info@vitec.ru)

### UNITED STATES

#### **Opto Engineering USA**

11321 Richmond Ave  
Suite M-105, Houston, TX 77082  
phone: +1 832 2129391  
[us@opto-engineering.com](mailto:us@opto-engineering.com)

### ASIA

#### **Opto Engineering China**

Room 1903-1904, No.885, Renmin RD  
Huangpu District 200010  
Shanghai, China  
phone: +86 21 61356711  
[cn@opto-engineering.com](mailto:cn@opto-engineering.com)

#### **Opto Engineering Taiwan**

Opto Engineering Southeast Asia LTD.  
4F., No.153, Sec. 2, Shuangshi Rd.,  
Banqiao Dist., New Taipei City 22043,  
Taiwan (R.O.C)  
phone: +886 282522188  
[tw@opto-engineering.com](mailto:tw@opto-engineering.com)

#### **Opto Engineering Japan**

*official partner*  
Optart Corporation  
4-54-5 Kameido Koto-ku  
Tokyo, 136-0071 Japan  
phone: +81 3 56285116  
[jp@opto-engineering.com](mailto:jp@opto-engineering.com)

#### **Opto Engineering Korea**

*official partner*  
Far Island Corporation Ltd.  
Seoil Building #703, 353 Sapyeong-daero,  
Seocho-gu, Seoul, Korea 06542  
phone: +82 70 767 86098  
+82 10 396 86098  
[kr@opto-engineering.com](mailto:kr@opto-engineering.com)